

SPÉCIFICATIONS TECHNIQUES

Caractéristiques	Modèle	CPCD30-XRW10
	Energie	Diesel
	Capacité (Q)	3000 Kg
	Centre de la charge (C)	500 mm
	Empattement (Y)	1700 mm
Poids	Poids	4380 Kg
Pneus	Type	Pneumatique
	Dimensions pneus avant	28x9-15-14PR
	Dimensions pneus arrière	6.50-10-10PR
Dimensions	Hauteur au toit (*cabine fermée)	h6 = 2150 mm
	Longueur hors tout	l1 = 3770 mm
	Largeur hors tout	B1 = 1225 mm
	Dimensions des fourches	1220 x 125 mm
	Garde au sol	m2 = 170 mm
	Rayon de braquage	Wa = 2400 mm
Moteur et transmission	Moteur	ISUZU C240
	Puissance moteur / fiscale	34.5 KW / 10 CV
	Nombre de cylindres / Cylindrée	4/2369 cm3
	Transmission	Powershift

Type	Modèle	Hauteur de levage maximale h3	Hauteur hors tout						Levage libre h2				Porte à faux avant		Inclinaison AV/AR (°)	Capacité					
			Mât abaissé h1	Mât déployé				Sans dossier		Avec Dossier		3t	3.5t	Centre de gravité à 500mm							
				Sans dossier		Avec Dossier		3t	3.5t	Roues simples				Roues jumelées							
				3t	3.5t/3.8t	3t	3.5t/3.8t			3t/3.5t/3.8t	3t			3.5t		3.8t	3t	3.5t	3.8t		
Mât duplex à visibilité libre	XR30/35M300	3000	2054	2169	3767	3842	4145	165	170	165	170	475	480	6/12	3000	3500	3800	3000	3500	3800	
	XR30/35M330	3300	2204	2319	4067	4142	4445	165	170	165	170	475	480	6/12	3000	3500	3800	3000	3500	3800	
Mât triplex libre	XR30/35N400	4000	2019	2069	4816	4891	5145	1188	1178	874	924	492.5	497.5	6/6	3000	3500	3800	3000	3500	3800	
	XR30/35N430	4300	2119	2169	5116	5191	5445	1288	1278	974	1024	492.5	497.5	6/6	3000	3250	3500	3000	3350	3700	
	XR30/35N450	4500	2169	2219	5316	5391	5645	1288	1328	1024	1074	492.5	497.5	6/6	3000	3150	3400	3000	3250	3600	

Courbe de charge chariot élévateur 3T

LIFHEIGHT ≤ 3m (kg)

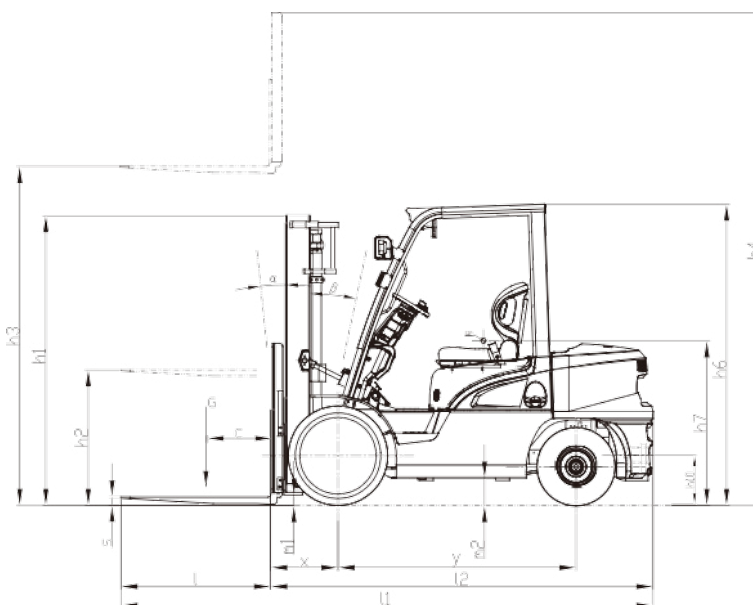
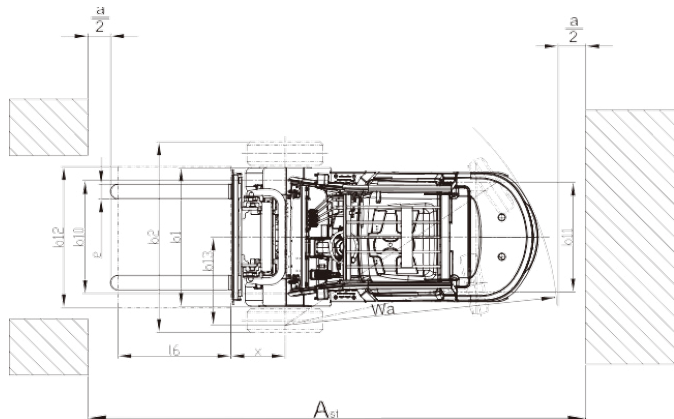
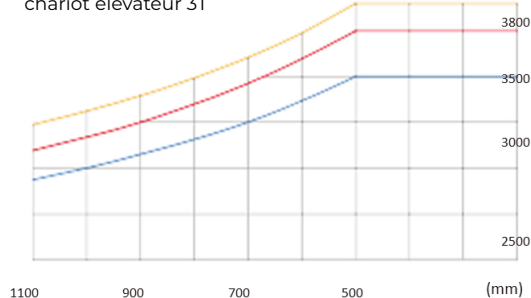



HANGCHA



CHARIOT DIESEL 3T

MOTEUR ISUZU



☎ 70 603 300

☒ 71 181 999

🌐 www.gam.com.tn

✉ gam@utic.com.tn

📍 Boulevard de la Qualité de vie

Z.I. Le Kram 2015 - Tunis